

- obsolete -

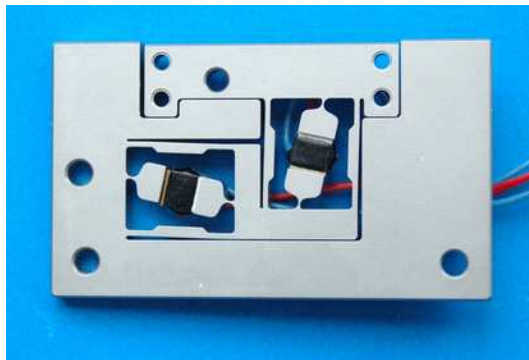

The positioning table is driven by two low voltage stacks and enables movement in x and y axes without feedback control. Electronic control for the table is provided by the *ase/nvs/g* group of components.

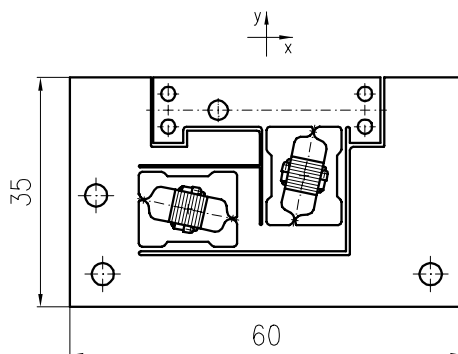

Technical data

L x W x H	(60 x 35 x 4) mm
Operating voltage:	160 V
Resonance frequency:	1.0 kHz
Displacement:	x direction 20 μm
	y direction 20 μm
Stiffness:	x axis 0.8 N/ μm
	y axis 0.4 N/ μm

The technical data was determined in conjunction with the control electronics *ase/nvs/g*.

Connection: 4 pins Molex-socket, stepping pitch 2,54

Pin	signal	function
1	uhvx	actuator operating voltage x, 0 ... +160 V
2	GND	actuator ground x
3	GND	actuator ground y
4	uhvy	actuator operating voltage y, 0 ... +160 V

Application

The piezoactuator-driven positioning table enables xy precision movement up to 20 μm , in laser scanners, mirror systems, for example.

Order Number	Release	Description
<i>asy/xyn/15/a</i>	1.1	Positioning table