

DN12/DN20

VALVE CARTRIDGE

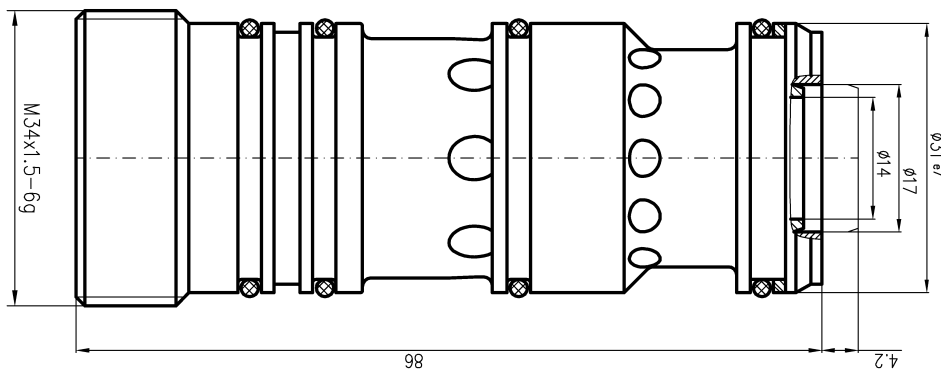

- marco block valve with nominal diameter 12 or 20
- The number of valve cartridges depends upon the number of functions required
- Constructed in one piece, optimised flow rate
- Easy to replace – high durability
- Stainless steel
- High quality seals
- Airtight even with low pressure differentials
- Sealing seat in high quality, strengthened plastic



Technical drawing of the *pm3/val/dn20/a* valve cartridge

DN12/DN20

VALVE CARTRIDGE

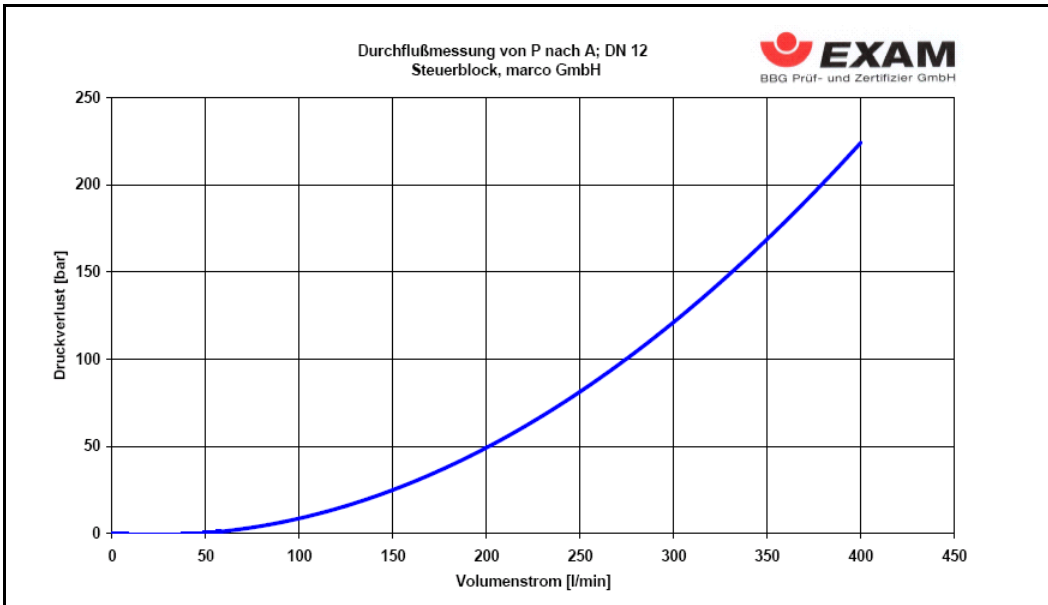

Flow rate measurement of the *pm3/val/dn12/a* valve cartridge

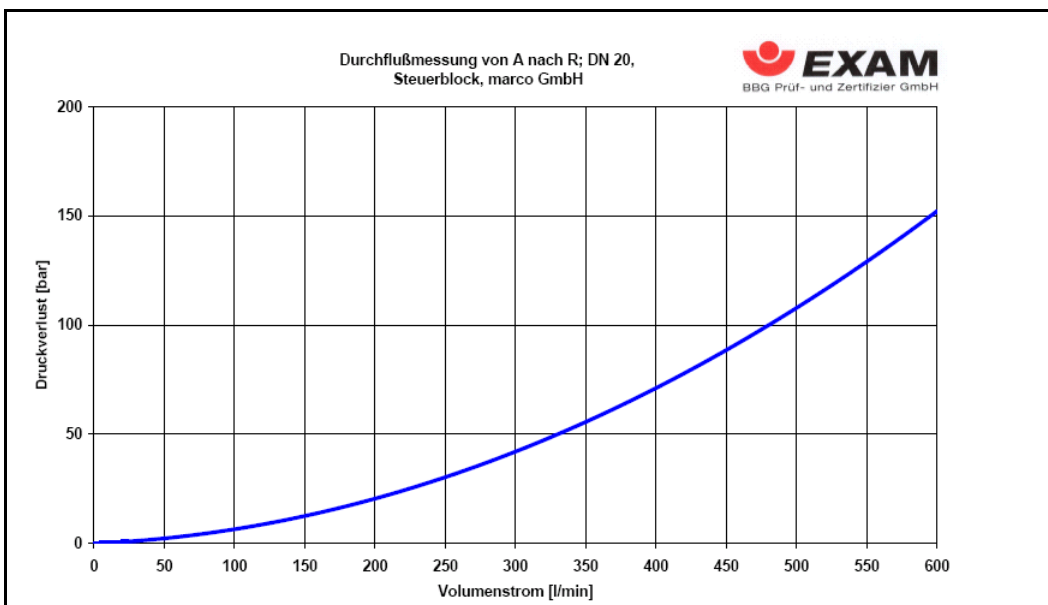

Flow rate measurement of the *pm3/val/dn20/a* valve cartridge

DN12/DN20

VALVE CARTRIDGE

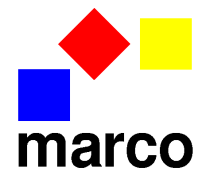

Hydraulic block with 18 functions

